

FU SHENG SR SERIES SCREW REFRIGERANT COMPRESSORS

A MASTERPIECE OF MODERN TECHNOLOGY WHICH OFFERS YOU
HIGH EFFICIENCY AND ENERGY-SAVING

Founded in 1953, Fu Sheng always strives to maintain a consistent managerial philosophy of pursuing excellence and enriching life. Fu Sheng has made every effort to ensure that customers are provided with compressors of the highest quality. After years hard work, Fu Sheng has been providing compressors in more than sixty countries all over the world.

Keeping growth is the basic condition of survival in the competitive market. For years, Fu Sheng has been keeping on improving manufacturing facility and technology. A plant automation project was initiated in 1987, which incorporated Managerial Information Systems(MIS), Engineering Information Systems(EIS) and Flexible Manufacturing Systems(FMS). With this integrated system, the management level is able to access the valuable information which benefits to the improvement of product design.

Advanced CNC Machining Centers and Rotor Milling Machines are used to manufacture compressors. All of the parts and casings of the compressor are precisely milled under humidity and temperature control room and then a sophisticated coordinate measuring machine is used to inspect the dimension of finished parts. Compressor rotors are dynamically balanced before assembly. Under Fu Sheng quality control system, every screw compressor shall be tested before shipment.

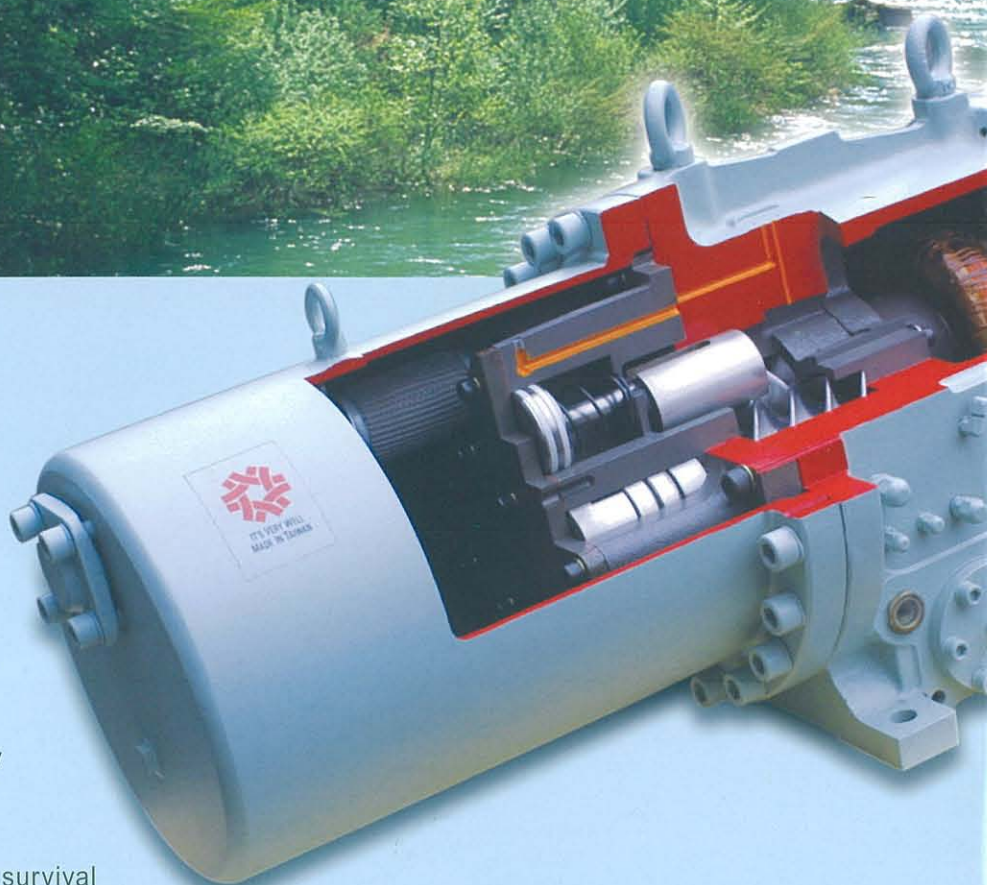

Coordinate Measuring Machine

All finished components are inspected to assure the highest quality of products.



Features

1 High EER, Low Energy Consumption

The newly asymmetrical rotor profile, which has five lobes and six flutes in the male and female rotors respectively, results in a low pressure differential between flutes and provides high volumetric efficiency but low power consumption.

2 Low Noise Level, Low Vibration

Rotors are precisely processed and dynamically balanced. Supported by high precise bearings, rotors can run smoothly.

3 Precise Capacity Control System

Four-step or linear capacity control system is available for operations under variable loading conditions with minimum power consumption.

4 Ease of Maintenance

With semi-hermetic design and limited components used, the detachable motor construction makes compressors easy to maintain.

5 Wide Application Range

The compressors can be widely used in water and air cooled air-conditioning systems, thermal storage system, heat pumps or industrial processes if external oil coolers, economizers or liquid refrigerant injection devices is equipped.



CNC Rotor Grinding Machine

With advanced CNC Rotor Grinding Machines, the rotor can be precisely processed.



Calorimeter

Experimental data always reflect the performance of a compressor. With this facility, engineers can easily get a lot of information of the compressors which is critical to optimize the design and improve the function of the compressor from time to time.

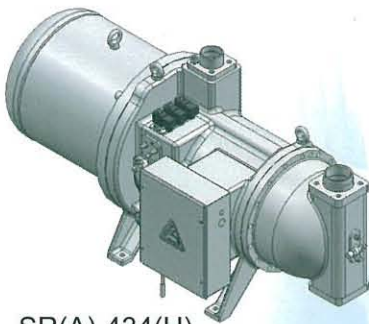

SR(A)-434(H)

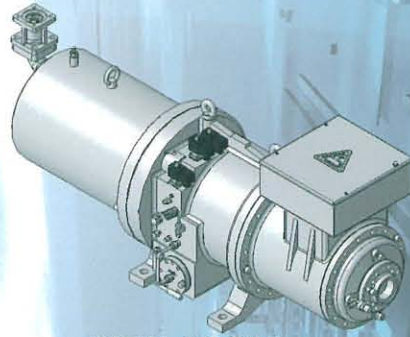

SR(A)-1,2,3(H)

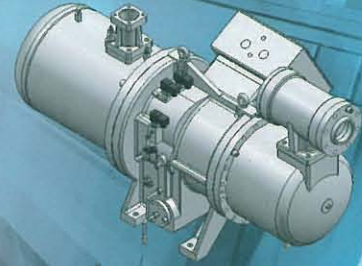

SR-4,5,561,6,7(H)

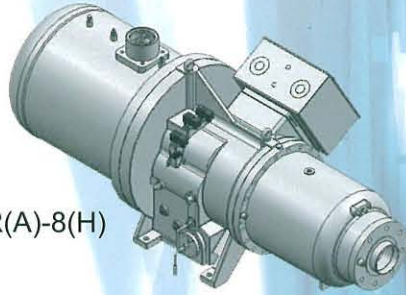

SR(A)-8(H)

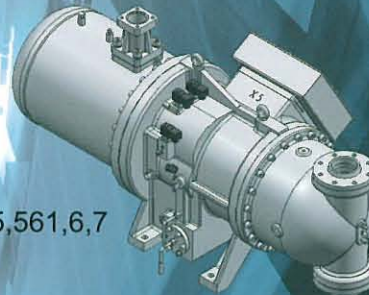

SRA-4,5,561,6,7

Application limits - Limites de funcionamiento - Champs d'application Einsatzgrenze - Limiti di applicazione

R-407C

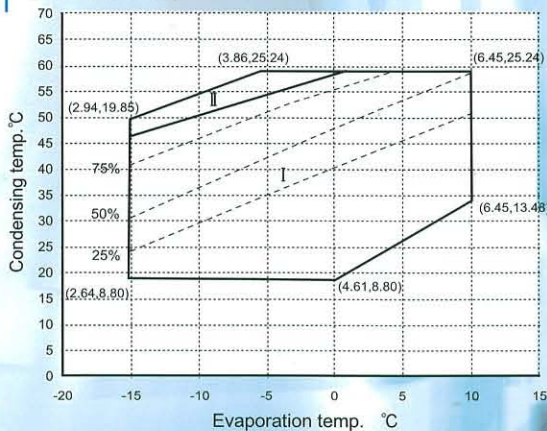

R-22

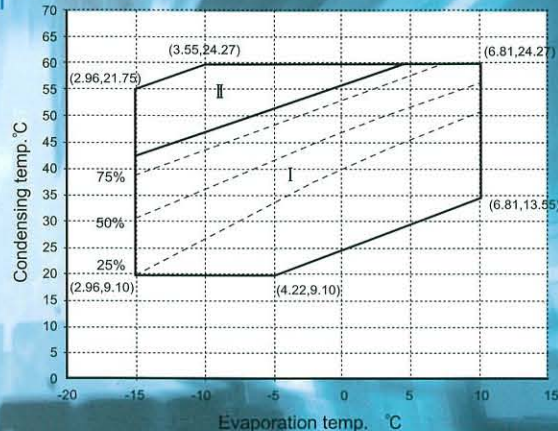

R-134a

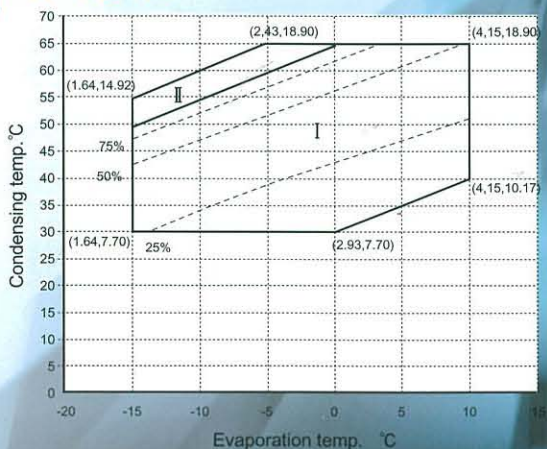

I Operation for water & air cooled application and heat pump - Funcionamiento por condensación de agua y aire y para bomba de calor - Fonctionnement pour condensation à eau ou air et pour pompe à chaleur - Wasser und luftgekühlter Betrieb und Wärmepumpen - Funzionamento per condensazione ad acqua ed aria ed a pompa di calore.

II Application limits, refer to instruction manual - Limites de funcionamiento, véase el manual de instrucciones - Champs d'application, voir manuel d'instruction - Einsatzgrenzen, siehe Bedienungsanleitung - Limiti di funzionamento, vedere manuale d'istruzione.

Outline dimensions-Dimensiones externas Dimensions d'encombrement-Äußere Abmessungen-Dimensioni esterne

Type-Tipo Mode'le-Typ-Tipo	A	B	C	D	E	F	G	H	I	J	K	M	L
SR-1(H), SRA-1	440	230	170	520	594	1336	578	260	448	24	235	---	405
SR-2,3(H), SRA-2,3	460	232	188	518	594	1451	629	317	455	24	235	---	485
SR-434(H), SRA-434	633	250	250	679	632	1440	634	420	277	18	300	699	358
SR-4(H)	817	315	225	751	840	1625	749	302	480	24	728	487	542
SRA-4	753	315	225	753	667	1557	749	302	394	24	325	487	478
SR-5, 561(H)	817	315	225	751	840	1657	749	334	480	24	728	487	542
SRA-5,561	750	315	225	753	672	1589	749	334	394	24	325	487	475
SR-6(H)	860	340	255	754	866	1722	848	284	561	26	754	530	577
SRA-6	817	340	255	757	667	1724	848	284	480	26	325	530	513
SR-7(H)	858	340	255	754	866	1753	848	319	561	26	754	530	577
SRA-7	814	340	255	757	672	1759	848	319	480	26	325	530	510
SR-8(H), SRA-8	930	310	285	771	747	2023	903	372	675	26	325	595	570

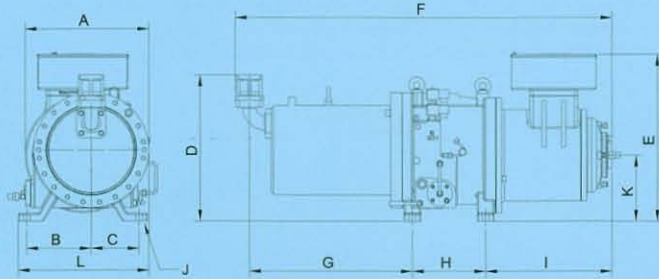

SR(A)-1,2,3(H)

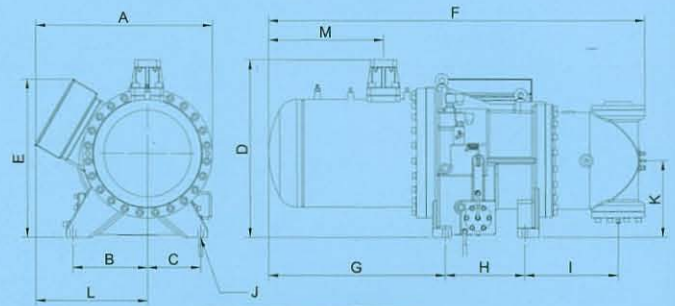

SRA-4,5,561,6,7

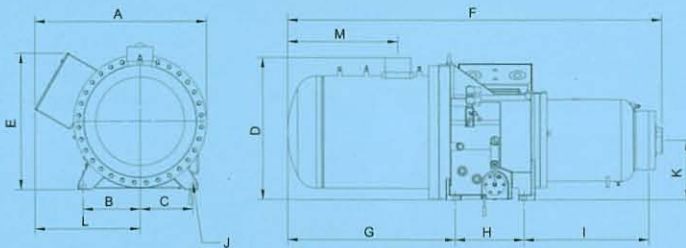

SR(A)-8(H)

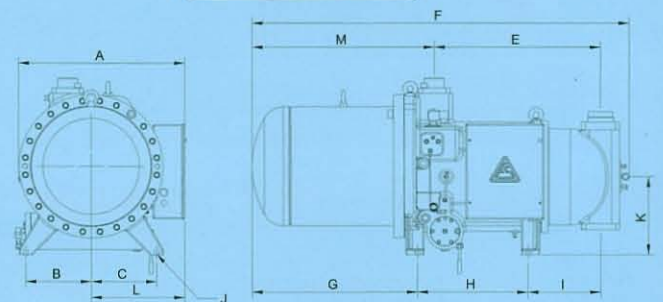

SR(A)-434(H)

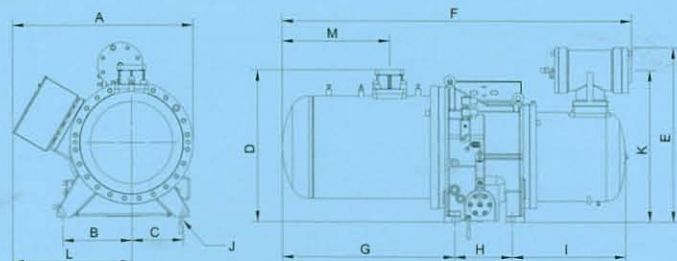

SR-4,5,561,6,7(H)

Fu Sheng reserves the right to change specifications and designs without notice.
 Fu Sheng se reserva derecho de realizar modificaciones en características técnicas y diseños sin previo aviso.
 Fu Sheng se réserve le droit de changer les devis techniques et les dessins sans aucune information préventive.
 Fu Sheng behält sich das Recht vor technische Angaben und Design ohne Vorankündigung zu ändern.
 La Fu Sheng si riserva il diritto di cambiare specifiche e disegno senza darne previa informazione.

Semi-hermetic Screw Refrigerant Compressor Specifications - Características Técnicas de Compresores Frigoríficos halbhermetischen Kaltkompressors - Caratteristiche

Model		SR-1(H)	SR-2(H)	SR-3(H)	SR-434(H)	SR-4(H)	SR-5(H)	SR-561(H)	SR-6(H)	SR-7(H)	SR-8(H)	
		SRA-1	SRA-2	SRA-3	SRA-434	SRA-4	SRA-5	SRA-561	SRA-6	SRA-7	SRA-8	
Capacity kW	*R22	50Hz	135	166	204	235	348	415	439	524	643	797
		60Hz	162	199	244	282	417	498	527	629	771	957
	*R134a	50Hz	89	110	131	162	236	277	292	355	404	542
		60Hz	106	132	157	195	284	333	350	426	485	650
	**R407C	50Hz	110	139	158	200	294	335	352	430	499	645
		60Hz	132	167	190	240	353	402	422	516	599	774
Displacement	m ³ /hr	50Hz	145.2	182.9	220.0	291.2	361.6	432.6	494.7	556.7	701.6	831.6
		60Hz	174.3	219.5	264.0	349.4	433.9	519.1	593.6	668.0	841.9	997.9
Male motor speed	RPM	3550/2950(60/50Hz)										
Capacity control	%	100/75/50/25(staring) or Linear capacity control (optional)										
Refrigerant		R-22/R-407C/R-134a										
Lubrication		Differential pressure feed lubrication										
Motor type		3 phases, 2 poles, induction motor										
Starting Method		Star-Delta starting										
Frequency	Hz	60/50										
Voltage	V	220,380,440,460 / 380~415										
Insulation		Class F										
Protection		Thermistor										
Oil heater	W	150					300					
Oil charge	Liter	9	11	11	13	13	13	13	19	23	23	
Weight for SR	kg	420	520	530	630	900	930	930	1,100	1,150	1,250	
Weight for SRA	kg	420	520	530	630	820	850	850	1,000	1,150	1,250	
Noise Level(maximum)	dB	79	81	81	83	86	86	86	86	86	90	

* **Capacity:** based on Cond. Temp. (Tc) 40°C., Evap. Temp. (Te) 2°C., Superheat 5°C., Subcooling 5°C. -**Capacidad:** con Temp. de Cond. (Tc) 40°C., Temp. de Evap. (Te) 2°C., Recalentamiento 5°C., Subenfriamiento 5°C. -**Puissance:** basée sur Temp. de Cond. (Tc) 40°C., Temp. de Evap. (Te) 2°C., Surchauffage 5°C., Sous-refroidissement 5°C. -**Bezugskonditionen:** Leistung Verflüssigungstemperatur (Tc) 40°C., Überhitzung (Te) 2°C., Verdampfungstemperatur (Te) 2°C., Unterkühlung 5°C. -**Capacità:** basata su temp. di condens. (Tc) 40°C., Temp. di Evap. (Te) 2°C., Surriscald. 5°C., Sottoraffr. 5°C.

** **Capacity:** based on Cond. Temp. (Tc) 50°C., Evap. Temp. (Te) 2°C., Superheat 5°C., Subcooling 5°C. -**Capacidad:** con Temp. de Cond. (Tc) 50°C., Temp. de Evap. (Te) 2°C., Recalentamiento 5°C., Subenfriamiento 5°C. -**Puissance:** basée sur Temp. de Cond. (Tc) 50°C., Temp. de Evap. (Te) 2°C., Surchauffage 5°C., Sous-refroidissement 5°C. -**Bezugskonditionen:** Leistung Verflüssigungstemperatur (Tc) 50°C., Verdampfungstemperatur (Te) 2°C., Überhitzung 5°C., Unterkühlung 5°C. -**Capacità:** basata su temp. di condens. (Tc) 50°C., Temp. di Evap. (Te) 2°C., Surriscald. 5°C., Sottoraffr. 5°C.



FU SHENG INDUSTRIAL CO., LTD.

HEAD OFFICE No.172, Sec.2, Nan-king E.Rd., Taipei, Taiwan 104

FACTORY No.60, Sec.2, Kwang-Fu Rd., Sanchung City, Taipei County, Taiwan 241
TEL:886-2-29951411 FAX:886-2-29997256

WEB SITE <http://machinery.fusheng.com>

E-MAIL machinery@m.fusheng.com.tw

714-0503-E03